

CASE STUDY
NO. 10

TWENTY SHORT CASE
PROBLEMS IN MATERIALS
HANDLING

Prepared by

<Authors'

Names>

<Name of Institute>

Copyright ©
1978

The Material Handling Institute

Introduction

Recognizing that improvements in productivity can be realized through innovation and application of the proper equipment at all levels of materials handling, the twenty short cases that follow have been developed for classroom use. The objective of these cases is to provide the student with an introduction to those types of handling problems encountered on a daily basis in industry.

Although these cases are very brief, they illustrate some commonly encountered operational and equipment oriented problems. A solution for each of these cases can be derived in a minimum amount of time. Ideally the cases will be used as points of discussion or assigned in groups as homework problems.

In a few of the situations presented, the full problem is not clearly defined and the student is challenged to solve whatever problems are apparent to him/ her after studying the case. Hopefully this approach will induce controversy, an essential element of the educational process.

Case 1

Situation: The Hawkins Supply company is currently faced with an inventory rotation problem. This difficulty stems from the fact that some supplies must be used prior to a stated expiration date. Upon receipt, a new shipment of these perishable items must be stacked beneath the boxes that are currently in inventory. A substantial amount of time is consumed in restacking the items according to their expiration dates.

Question: The company would like to reduce the double and sometimes triple handling of items. How can this goal be achieved? Are there alternative solutions which might also be effective?

Case 2

Situation: The JAW Bottling company has recently introduced a new beer to the market called HEAVY. It is extra high in calories. It has been developed specifically for those people that enjoy feeling full after only one beer.

The materials handling supervisors at JAW Bottling have been receiving complaints from lift truck drivers that cases of the new HEAVY beer are slipping off pallets during intra-plant movement and truck deliveries.

Thus far the JAW engineering department has tried to eliminate or reduce case slippage through the use of the following methods:

1. Top case clamp on the fork truck.
2. Strapping cases to pallet.
3. Plastic wrapper around cases.
4. The use of a large size pallet with a retainer strip nailed along the edges.

Question: Using a method other than those described above, can the case slippage problem be solved?

Case 3

Situation: Field, Bell and Weiss, a consulting firm, has been engaged by the Fizzle Beverage Company to determine possible methods for expanding their warehouse facilities. The current warehouse has 16' ceilings with a possible 10' clear stacking height. At the 10' level the obstructions are steam pipes, lighting fixtures and air ducts.

Fizzle Beverage currently receives all pallets by truck. Each pallet load is 6' high (including the pallet). In order to take full advantage of all available height the second level pallet in each stack must be broken down.

Question: How could Fizzle increase storage capacity?

Case 4

Situation: The Acme Warehouse Company received a consignment of 20' lengths of 3" diameter stainless steel pipes. Acme had never handled pipe as part of their warehousing operation. The forklift truck operator assigned to this job used the truck's forks as a ram to load, handle, and unload the pipe. Inspection of the pipe by the owners revealed that the forks were bending and damaging the pipe.

Question: Suggest several alternative methods for eliminating the problem of pipe damage. From a cost and ease in application standpoint, select one alternative solution for adoption.

Case 5

Situation: The Free Wheelin Car and Foundry Company is in the business of modifying and repairing the coupler pins on railroad cars. Due to the nature of the mechanism the complete coupler assembly must be removed from the car. Once detached, an overhead gantry crane is used to lift and move the coupler to a location adjacent to the car being repaired. Because of the various uses of this crane, many scheduled operations must be delayed.

Question: Preliminary investigation indicates that the super-structure is very sound with columns placed on 20' centers. Suggest an approach for the reduction or the elimination of the delays currently being experienced in the gantry crane operations.

Case 6

Situation: The Jones Company operates a centrally located storeroom in their manufacturing complex. Every afternoon each craft foreman (Tin Shop, Electric Shop, Iron Workers, etc.) writes a requisition for common use items that will be required for the next day's work. These common use items include nuts, bolts, screws, washers, flashlight batteries, and gloves. All specialty items are ordered separately.

During the night shift, storeroom personnel fill the orders of items requested by the craft foreman. Each morning, one or two workers from each department go to the storeroom with a four-wheel platform truck to pick up the filled order.

Question: Although studies have never been performed to determine the amount of time craftsmen spend waiting for supplies, it is the thoughts of the management that idle craft manpower is a problem resulting from this procedure. How can time spent traveling to and from the described storeroom be reduced, thus, eliminating or decreasing crafts' personnel travel time?

Case 7

Situation: The Sure To Peel Paint Company stores all its metal compressed gas containers in a warehouse. These long cylindrical metal tanks contain various gases used in manufacturing cans of spray paint. The gas tanks are delivered to the warehouse by truck. Two receiving dock workers unload the containers from the delivery trucks and place them on four wheel trucks. Two materials handlers are responsible for pushing the loaded trucks into the warehouse, unloading the tanks and setting them up on end. The two materials handlers spend a major portion of their day moving loads of the gas tanks into the warehouse and placing them into the proper storage locations. In total, there are five different types of gases that in equal proportion make up 98% of all gas handled.

Question: Management would like to identify a better way to handle these gas tanks. How can the handling operation be improved?

Case 8

Situation: The White Manufacturing Company produces a spring-loaded replacement spike for power rakes. Because of the small size of this item, they are packaged in separate small containers that are in turn packed into a larger carton (24 count) for shipping. The packing operation for this unit is on the third floor of a multi-story building.

Upon completion of the packing operation the shipping cartons are placed on semi-live skids and taken to the second floor using an elevator. The same elevator is also used to move other materials to various floors in the plant for processing. On the second floor packages are sorted according to trucking line. After sorting, all packages are placed on a semi-live skid and moved to the first floor via the same elevator. On the first floor, the packages are stored awaiting shipment (pick up by the assigned truck line).

Question: Disregarding labor requirements, how can the movement of packages be improved?

Case 9

Situation: The R-Way Distributing Company fills orders from one to one hundred items ranging in size from 3" x 4" x 6" to 3' x 3' x 3'. All orders are put into packing cartons and shipped by commercial carriers. The packaging operation is performed by two workers on flat waist-high work benches. Two workers are required because of the size of some of the cartons. To secure the packages, rope, strapping, filament tape or gummed tape is used. The wrapping operation is completely manual. After a package has been packed, wrapped and sealed, it is hand-carried to classified shipping bins about 400 feet from the wrapping tables.

Question: How can the packaging operation be improved? Suggest methods or equipment for improving the handling of packages.

Case 10

Situation: The Acme Tube Company has for the last 10 years used 42" square reusable wooden boxes to ship custom length short tubing. During the past year the unit cost of a shipping box has soared from \$14.50 to \$40.00 per unit. In addition, box maintenance has gone up from \$5 per year to \$22 per year.

Reusability has turned into a cost trap for Acme. Extra truck runs and outside trucking services are being employed to recover the returnable wooden boxes since on return trips the firm's trucks are needed to pick up raw stock.

Another major problem being faced is that warehouse space is getting very scarce but to operate Acme must have an inventory of about \$10,000 worth of wooden boxes in the system at all times.

Question: As a material handling engineer, how would you improve this system? Give a detailed description of a possible new method for shipping the tubes.

Case 11

Situation: The Allen Export Company ships sugar to many overseas ports. Over the years the company has stacked large bags of sugar onto pallets for shipping. Because of a lumber shortage, pallets for export have become very difficult to obtain. The management of Allen Export has presented the dock manager with the challenge of reducing the number of wooden pallets used and/ or to find a new way to supplement or change their stevedoring system.

Question: Can a system be devised to eliminate the shortage of pallets?

Case 12

Situation: The storage area of the P.D. George Company is presently filled to capacity with 25,000 items. The plant has recently increased its manufacturing capability by 100% and the finished goods inventory is expected to increase by the same ratio. The present storeroom is 150' by 275' with a 30' ceiling height.

Due to the features of the product line it is not advisable to stack the 15" x 25" x 12" cases more than 6 high without racks for support. The George Company does not use racks in the inventory area.

Question: Suggest methods for increasing the storage area to accommodate the contemplated increase in finished goods inventory.

Case 13

Situation: The Double Rite Bottling Company delivers soda to vending machines throughout the northern section of Rhode Island. The Company takes pride in the fact that all the beverages are sold in returnable bottles. The president of Double Rite feels it is his civic duty to help decrease the roadside trash that is often attributable to disposable beverage cans.

The returned empty bottles are stored on the roof of the truck when the driver is making his deliveries.

Upon returning to the warehouse after deliveries are made, a helper passes the empty cases from the roof of the truck to the driver standing on the ground. The driver then places the cases onto a conveyor.

Question: How can the handling of empty cases from the roof of the truck be accomplished in a more economical manner?

Disregard the handling of empty cases in the body of the truck.

Case 14

Situation: The Globe Can Company presently moves pallet loads of cans from production to the truck dock for loading. The loading dock foreman claims that due to increased production the company needs to purchase five new fork trucks and to hire five persons to operate these trucks.

Using the present equipment (fork trucks) the maximum load of cans that can be transported is 1500 lb. at a 13.5" load center. The fork truck currently in use is manufacturer-rated for 3,000 lb. at the 24" load center.

Question: Can the pallet load capacity be increased? What, if any, new equipment is required?

Case 15

Situation: The Rosemarie Cosmetic company has a warehouse of 20 high pallet racks serviced by counter-balanced fork trucks. The aisles between racks are 12 feet wide.

Storage space has become a premium with new product lines being added. A warehouse expansion is currently being planned.

Question: How can the warehouse handling system be improved without expanding the warehouse?

Case 16

Situation: The Sunbright Cabinet Company manufactures kitchen cabinets for home use. The cabinets vary in size according to customer specifications. The upper and lower limits on the width of the cabinets are 7' x 3'. When fully assembled these cabinets are placed in cardboard containers. Each cabinet is mounted on a skid before being prepared for shipping.

Depending on the dimensions of a cabinet it can weigh from 45 lb. to 180 lb. Movement around the plant is done on semi-live skids. The loading of delivery trucks for shipment to distributors is a completely manual operation.

Question: Can this handling method be improved? Suggest methods for reducing or eliminating container deadweight.

Case 17

Situation: The Frigid-King Company manufactures refrigerators, deep freezers and other like porcelain-coated appliances. They have sub-contracted the Sturdy-Crate Company to make the crate base for the refrigerators. The Sturdy-Crate Company contract calls for the furnishing of the material, labor, and storage of the finished base. The finished base is to be stored until ordered by Frigid-King.

The storage at the Sturdy-Crate Company is based on a cube size of 48" x 36" deep and 72" high.

Presently the cleats, runners and crate bases are handled using a four-wheel platform truck.

Question: In order to set up an improved operation, the following questions are asked:

- A. If the cleats and runners were palletized or unitized at the lumber mill, what would be the design and size of the load?

A-1 Runners A-2 Cleats

- B. If the completed crate bases were palletized or unitized what would be the design and size of the load?

- C. From the data determined in A, how many runners and cleats could be placed in a railroad car of each lumber component? Assume the railroad car size is 50'L x 9'W x 10'6"H inside dimension with the door being 8'W x 10'H.

- D. From the data determined in B, how many completed crate bases could be loaded into a tractor trailer? Assume the truck is 39'L x 90"W x 96"H inside dimension with the rear door size of 90"W x 93"H.

The present layout of the Sturdy-Crate Company and the completed crate bases are shown in Figure 1 and Figure 2 respectively.

Figure 1.
LAYOUT OF THE STURDY-CRATE CO.

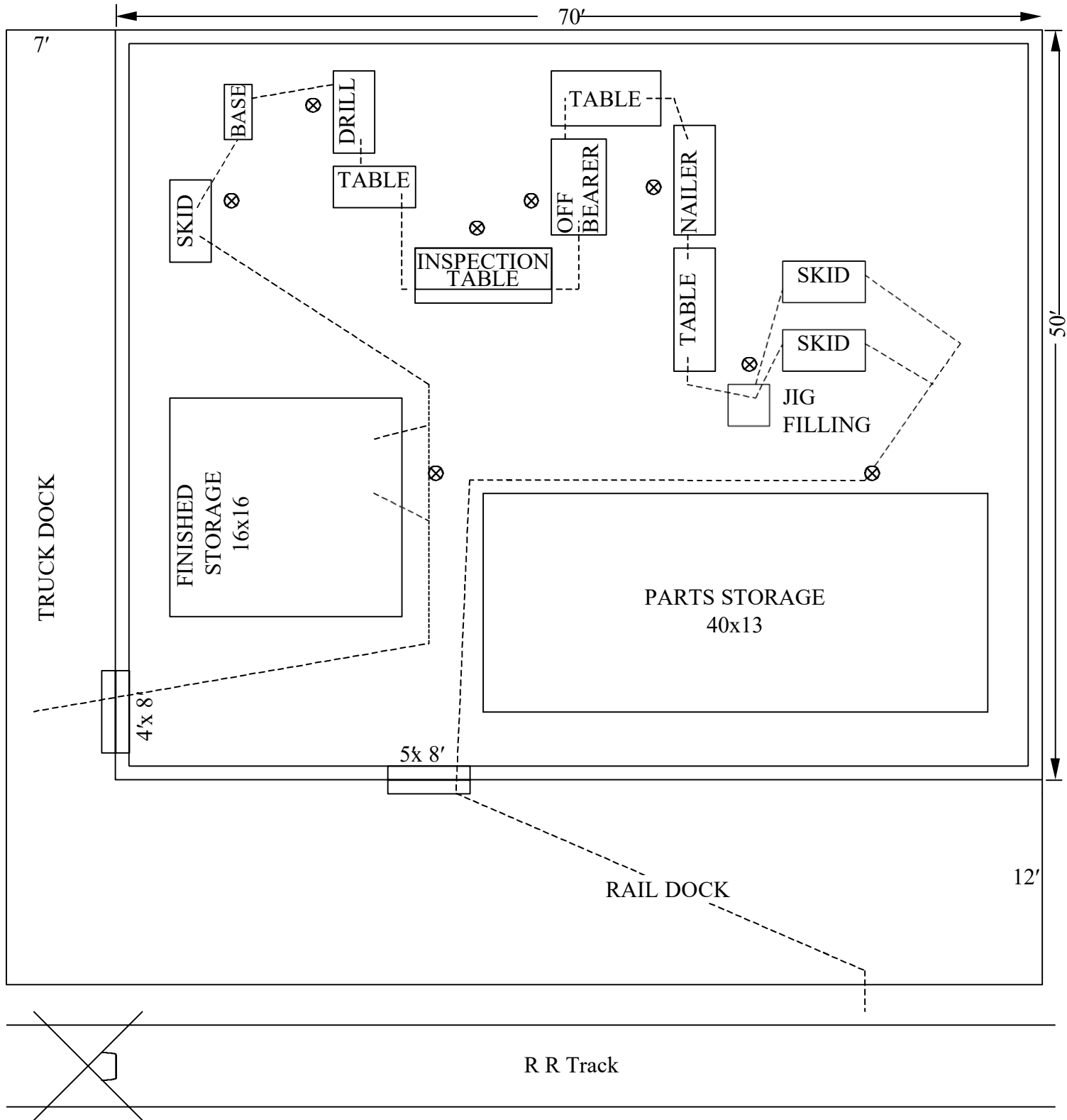

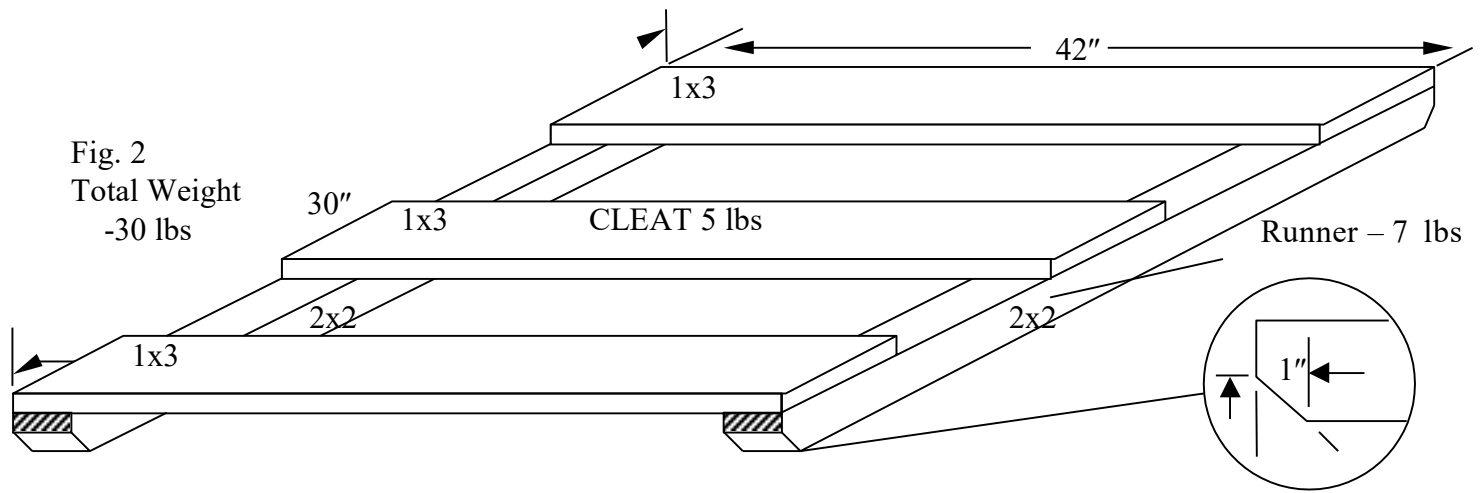

Fig. 2
Total Weight
-30 lbs

STURDY-CRATE CO.

Completed Crate Bases

Case 18

Situation: Hughes Distributing Company, a southwestern distributor of health and beauty supplies is faced with a housekeeping problem in their receiving areas. On several visits to these departments, the plant engineer has found them cluttered with trash and empty cardboard shipping cartons. An examination of the receiving operations indicates that when a large shipment of material is received the items are removed from their shipping cartons and placed on racks. The empty cartons and packing materials are left on the floor. Periodically, or when the order unpackers cannot move, someone flattens and stacks these refuse materials.

Question: Suggest a method for reducing or eliminating this housekeeping problem.

Case 19

Situation: Intercity Transportation Company Incorporated specializes in transporting bottled beverages. The company is currently experiencing difficulty in moving pallet loads of bottles from railroad cars into trucks.

At the present time a 24-hour (3-shift) operation is maintained. Empty bottles arrive at the plant in railroad cars - three pallets wide in the car. The pallet size is 32" x 37" (block). The pallets are stacked in the railroad car on the 32" side and must be loaded into the trailer on the 37" side. The handling of pallets from the car to the trailer is performed by fork truck. There is a constant supply of railroad cars and trailers.

Handling Operation

The fork truck picks up a pallet in the rail car (0 ft. - 1.5 min.), moves to an open area in the warehouse (20 ft. - 1.25 min.), and drops the load. Backing out of the load entering and picking up the load from the other direction (0 ft - 0.75 min.), the load is then moved to a waiting trailer (30 ft. - 0.30 min.) and the load is placed into the trailer (20 ft. - 0.30 min.). The fork truck then returns to the railroad car and picks up the next pallet load (70 ft. - 2.00 min.). This operation is repeated for each pallet load. A trailer load is 26 pallets and the railroad car contains 39 trailer loads. The present load patterns in the railroad cars and trailers cannot be changed.

Question: Determine the time to place a pallet into the trailer. Using the calculated time as a base time, suggest methods for improving the operation.

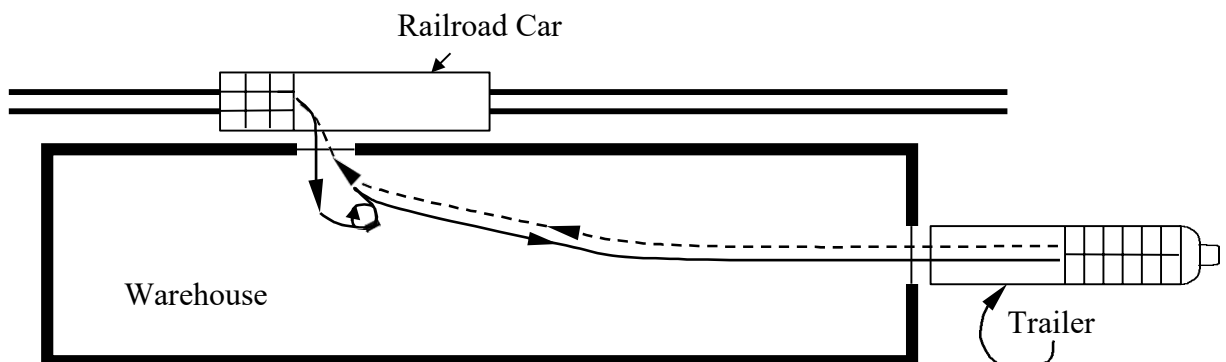

Case 20

Situation: The A-B Manufacturing Company receives cans used to package their fruits in re-shipper cartons. These cartons cannot be reused and are sent to a paper baler where they are baled and in turn placed in a railroad car.

Six freight handlers earning \$5.25 per hour remove from the paper baler a bale of compressed cartons. Each bale is 33" x 46" x 84" with a weight of 735 lb. Each bale is wire-strapped. The six freight handlers remove the bale from the baler and place it on a four-wheel hand truck. All six handlers pull and push the truck to the railroad car where they place it into the car. This operation is repeated until the car is loaded. The capacity of the railroad car is 30 bales for a standard 40'6" car with a 6'8" wide door. Eight hours per day is a standard work shift.

The handlers have a 20 minute lunch and 20 minutes for coffee leaving a total of 440 minutes remaining for operational work.

The present operation, distance, and time per bale are:

# of Handlers	Time per Bale (min.)	Distance (ft.)	Description of Task
6	1.0	8	Remove bale from baler to four-wheel hand truck.
4	0.5	-	Close baler doors
2	0.5	-	Insert wire for next bale.
6	4.0	56	Move bale on truck to railroad car.
6	1.0	10	Remove bale from truck.
6	2.0	2	Stack bale in railroad car.
2	6.0	78	Move empty truck to baler.
2	0.5	-	Open baler.
2	0.5	-	Fix and lock wire strapping.

(Compression time per bale is 12 minutes.)

Question: How can you make this operation more efficient using modern material handling methods? Do not consider the loading of the baler as part of the problem. Also, the location of the baler cannot be changed.